

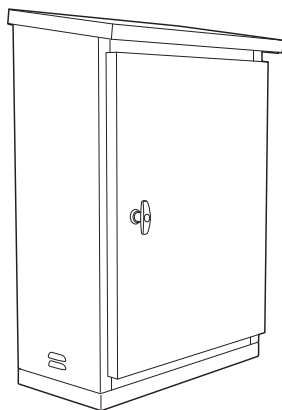

Operating & Maintenance Manual

Glasdon Housings & Cabinets

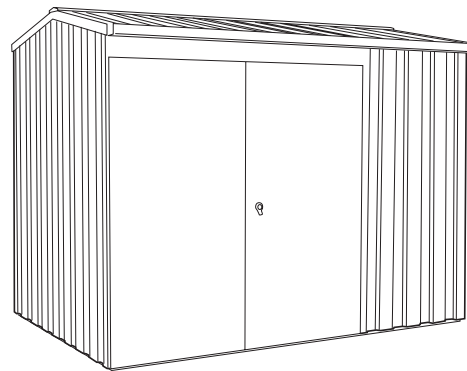
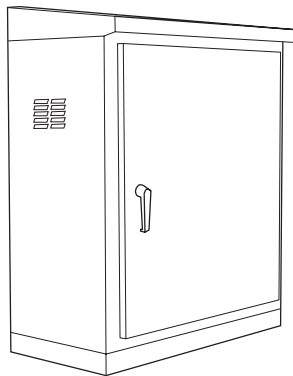
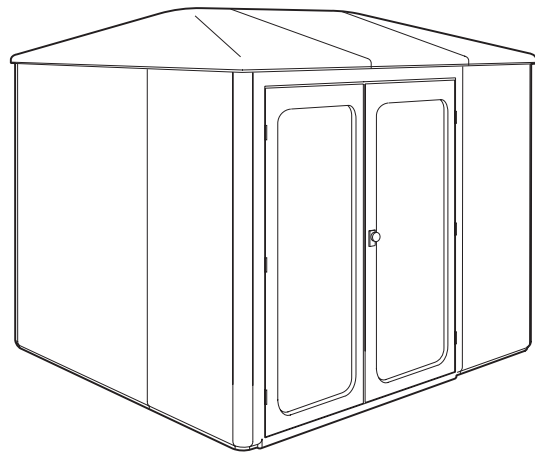
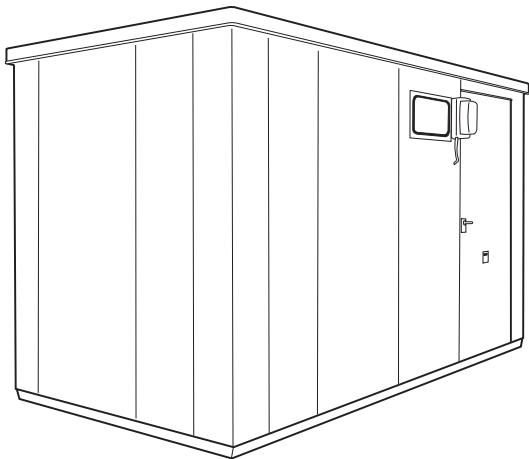

Glasdon U.K. Limited

Preston New Road
BLACKPOOL
Lancashire
FY4 4UL

Tel: (01253) 600410

Fax: (01253) 792558

e-mail: sales@glasdon-uk.co.uk

web: www.glasdon.com

Operating & Maintenance Manual

Thank you for purchasing a Glasdon product. This manual contains important information for the installation and future care of your product.

Content

- Chapter 1 Installation
- Chapter 2 Electrical Installations
- Chapter 3 Base Fixing Guidelines
- Chapter 4 Future Care of Your Product
- Chapter 5 Handling & Moving Your Product

Should you require any further assistance please contact us on
tel: 01253 600410, fax: 01253 792558 or email: sales@glasdon-uk.co.uk.

1 Installation

We recommend that all Glasdon Housings are permanently sited and fixed down to a prepared concrete base at the time of delivery using fixing bolts supplied.

Installation guidelines are contained in Chapter 3. To ensure satisfactory operation of door locks after installation, it is very important to keep door frames square and level during base fixing.

If a panel form delivery option has been arranged for assembly by yourselves following agreement with our Sales and Technical Department, you will find a comprehensive instruction booklet enclosed with this manual.

If your Housing has been manufactured to a customised design there should also be a CAD drawing of the layout enclosed for your reference.

If your Housing has been fitted with sanitary ware such as wash hand basins and sinks, you may have opted for the relevant pipework and fittings to be pre-installed at our factory rather than making your own arrangements with a local plumber. The final site connection to the water supply and waste system should always be arranged locally by yourselves and all pre-installed pipework and fittings thoroughly checked on site before use.

In the event that installation of your Glasdon Housing does not take place at the time of delivery, suitable temporary storage arrangements must be made by yourselves to prevent damage being sustained either by adverse weather conditions or other influences.

Glasdon cannot accept responsibility for:

1. Damage to Glasdon Housings which are not permanently sited and installed at the time of delivery.
2. Damage caused by insecure storage or careless handling.
3. Re-delivery costs due to failure to install immediately or provide adequate storage.

2 Electrical Installations

For Housings that are fitted with an electrical installation we usually issue the original factory test certificate separately by post to your correspondence address. You will also find a copy of the certificate enclosed with this manual.

General technical information and individual operating instructions are enclosed for your future reference for the electrical components fitted within your Housing, e.g. consumer units, electrical sanitary ware and pipework etc, should be arranged locally by yourselves.

We recommend that all electrical installations are inspected annually by a suitably qualified and competent person.

3 Base Fixing Guidelines

Fortress

Base Requirements

The minimum base size required is 250mm greater than the nominal internal housing size. Assuming not suitable existing surface, the base should be a minimum of 125mm concrete on the well consolidated hardcore. The concrete should be of minimum C20/25 grade in accordance with BS8500 Concrete: The Complementary British Standard to BS EN 206-1.

The base should be flat, steel float finished, level and square and preferably be raised slightly above the surrounding ground level.

Roof and Base Fixing Detail

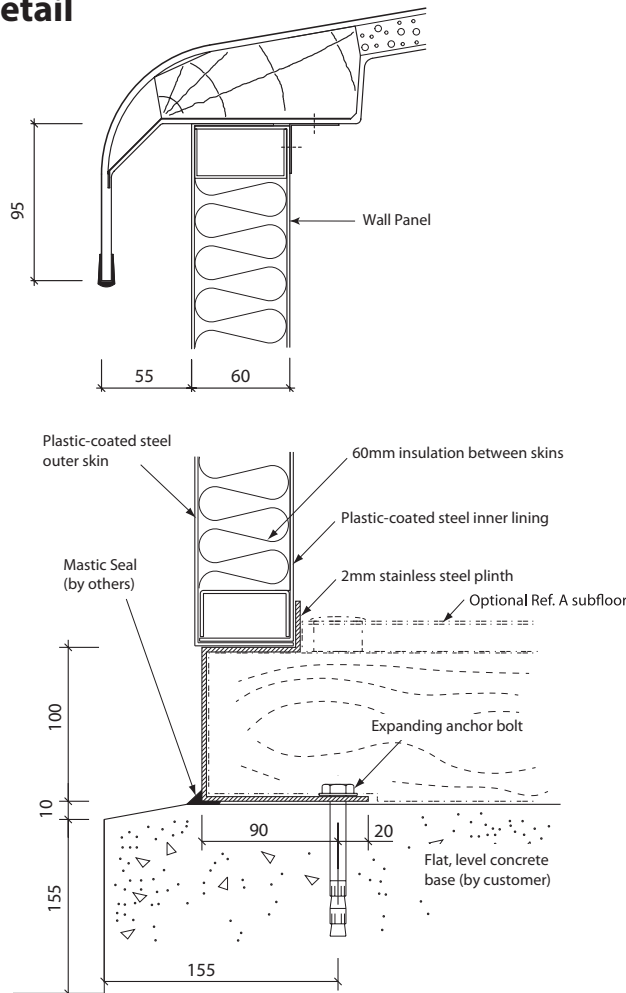

Base Fixing

Ensure that the panels are accurately aligned and the housing is completely square, i.e. the corners are at 90° and the diagonal dimensions are exactly the same.

Base fixing (by our customers) is accomplished using the expanding anchor bolts supplied. Refer to the base fixing instructions supplied with the fixings for correct installation in accordance with the manufacturer's recommendations.

Finally, apply an external mastic seal to the perimeter of the housing.

Garrison

Base Requirements

The minimum base size required is 250mm greater than the nominal internal housing size. Assuming no suitable existing surface, the base should be a minimum of 125mm concrete on to well consolidated hardcore. The concrete should be of minimum C20/25 grade in accordance with BS8500 Concrete: The Complementary British Standard to BS EN 206-1.

The base should be flat, steel float finished, level and square and preferably be raised slightly above the surrounding ground level.

Roof and Base Fixing Detail

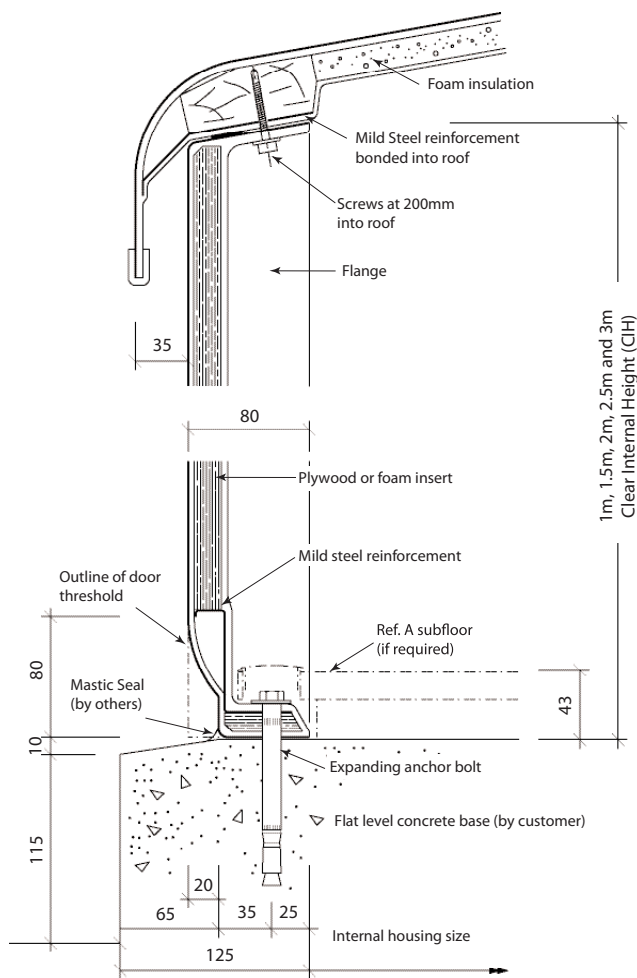

Base detail at double door threshold

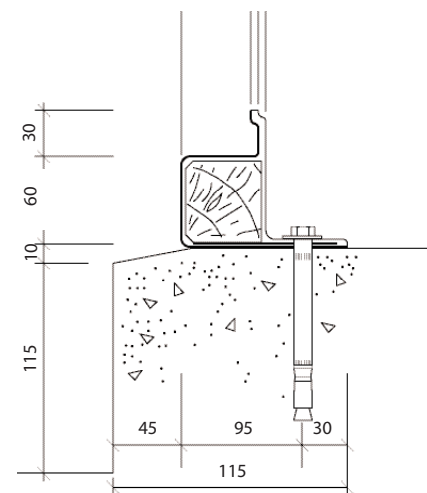

Base Fixing

Ensure that the panels are accurately aligned and the housing is completely square, i.e. the corners are at 90° and the diagonal dimensions are exactly the same.

Base fixing (by our customers) is accomplished using the expanding anchor bolts supplied. Refer to the base fixing instructions supplied with the fixings for correct installation in accordance with the manufacturer's recommendations.

Finally, apply an external mastic seal to the perimeter of the housing.

Trooper / Defender

Base Requirements

The minimum base size required is 100mm greater than the overall size of the housing. Assuming no suitable existing surface, the base should be a minimum of 125mm concrete on to well consolidated hardcore. The concrete should be of minimum C20/25 grade in accordance with BS8500 Concrete: The Complementary British Standard to BS EN 206-1.

The base should be flat, steel float finished, level and square and preferably be raised slightly above the surrounding ground level.

Base Fixing Detail

Trooper

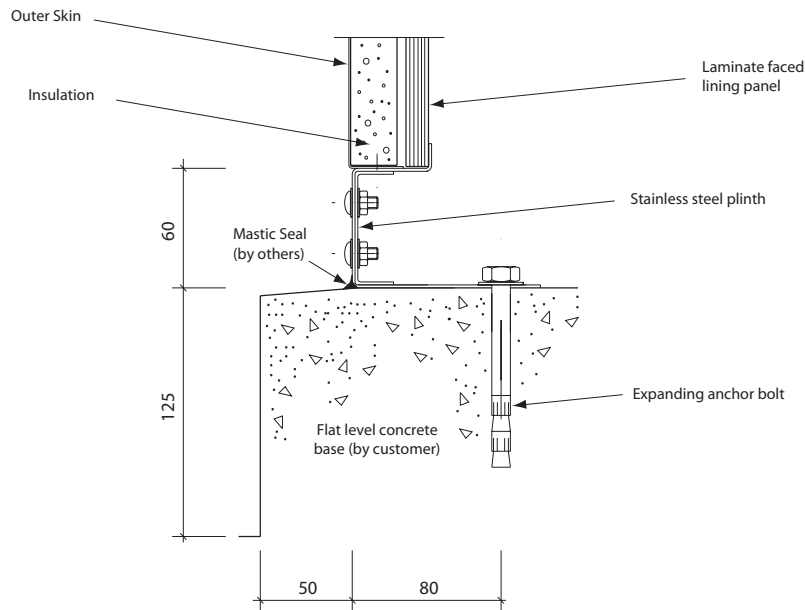

Defender

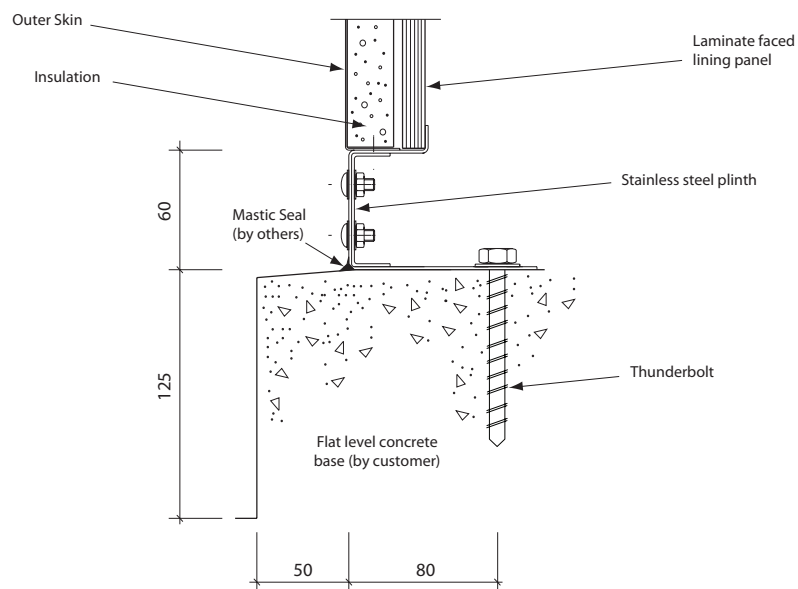

Base Fixing

Ensure that the panels are accurately aligned and the housing is completely square, i.e. the corners are at 90° and the diagonal dimensions are exactly the same.

Base fixing (by our customers) is accomplished using the anchor bolts supplied. Refer to the base fixing instructions supplied with the fixings for correct installation in accordance with the manufacturer's recommendations.

Finally, apply an external mastic seal to the perimeter of the housing.

Cadet

Base Requirements

The minimum base size required is 100mm greater than the overall size of the Cadet Cabinet. Assuming no suitable existing surface, the base should be a minimum of 125mm concrete on to well consolidated hardcore. The concrete should be of minimum C20/25 grade in accordance with BS8500 Concrete: The Complementary British Standard to BS EN 206-1.

The base should be flat, steel float finished, level and square and preferably be raised slightly above the surrounding ground level.

Base Fixing Detail

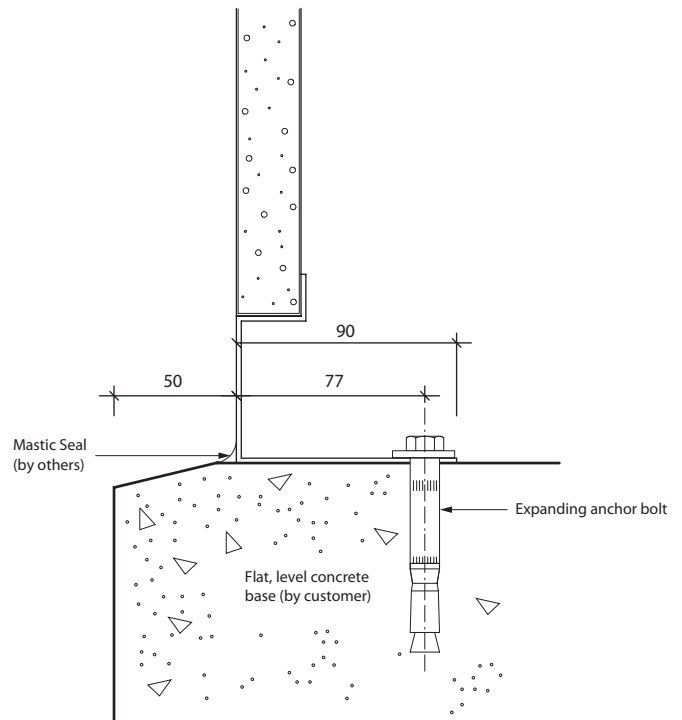

Citadel

Base Requirements

The minimum base size required is 100mm greater than the overall size of the Citadel Cabinet. Assuming no suitable existing surface, the base should be a minimum of 125mm concrete on to well consolidated hardcore. The concrete should be of minimum C20/25 grade in accordance with BS8500 Concrete: The Complementary British Standard to BS EN 206-1.

The base should be flat, steel float finished, level and square and preferably be raised slightly above the surrounding ground level.

*Please refer to the **Fixing Installation Instruction Manual** for installation of the Concrete-in Anchor with Locator Plate Fixing Kit.

Base Fixing Detail

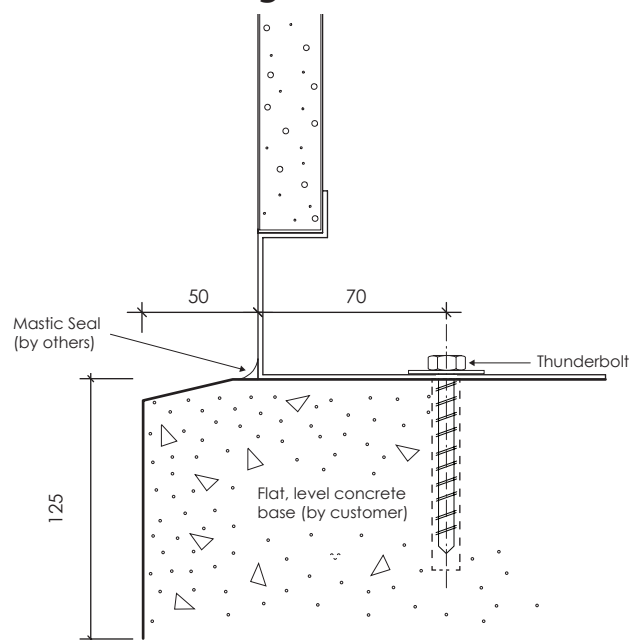

Base Fixing

Ensure that the panels are accurately aligned and the housing is completely square, i.e. the corners are at 90° and the diagonal dimensions are exactly the same.

Base fixing (by our customers) is accomplished using the anchor bolts supplied. Refer to the base fixing instructions supplied with the fixings for correct installation in accordance with the manufacturer's recommendations.

Finally, apply an external mastic seal to the perimeter of the housing.

Hermit

Base Requirements

Assuming no suitable existing surface, the base should be a minimum of 125mm concrete on to well consolidated hardcore. The concrete should be of minimum C20/25 grade in accordance with BS8500 Concrete: The Complementary British Standard to BS EN 206-1.

The base should be flat, steel float finished, level and square and preferably be raised slightly above the surrounding ground level.

Base Sizes

220 Models	-	2195 x 2080mm
320 Models	-	3195 x 2080mm
330 Models	-	3195 x 3080mm
430 Models	-	4195 x 3080mm
530 Models	-	5195 x 3080mm

Base Fixing Detail

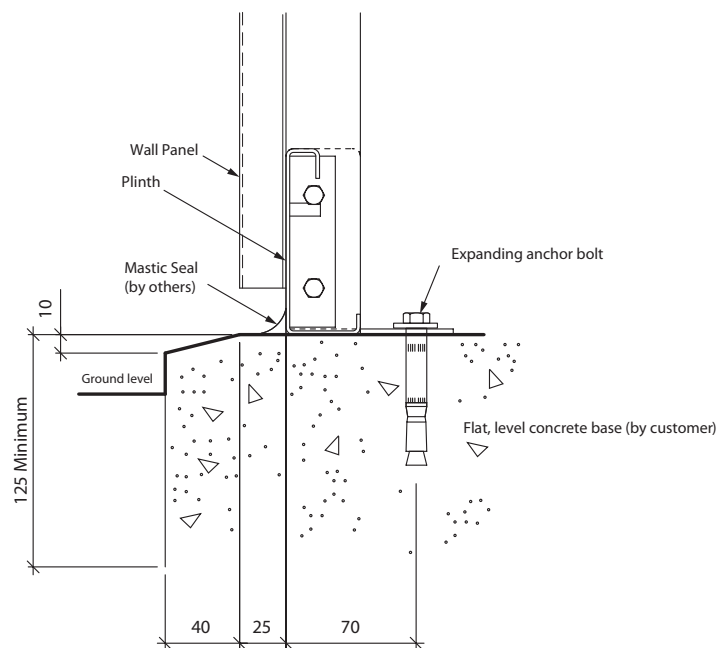

Base Fixing

Ensure that the panels are accurately aligned and the housing is completely square, i.e. the corners are at 90° and the diagonal dimensions are exactly the same.

Base fixing (by our customers) is accomplished using the expanding anchor bolts supplied. Refer to the base fixing instructions supplied with the fixings for correct installation in accordance with the manufacturer's recommendations.

Finally, apply an external mastic seal to the perimeter of the housing.

4 Future Care Of Your Product

All Glasdon products are manufactured using only the highest quality materials and are designed to provide the very best value for money with years of trouble-free service. To help preserve the life of your Glasdon Housing and keep it in pristine condition, we recommend that regular cleaning is arranged as part of your routine site cleaning programme.

The frequency of cleaning will depend on the prevailing site conditions, e.g. industrial and marine environments are likely to need more frequent cleaning than rural environments.

Standard Construction Materials

PRODUCTS	INTERNAL & EXTERNAL SURFACES			GLAZING	
	GRP Walls or Roof	Plastic-Coated Walls or Roof	Laminate Internal Walls	Flecked Paint Internal Walls	Toughened Glass or Thermoplastics
Fortress	.	.			.
Garrison	.			.	.
Defender		.			
Cadet		.			.
Citadel		.			
Hermit		.			.

Routine Cleaning for Standard Materials

a) EXTERNAL SURFACES

- GRP

Wash using a soft sponge mop and plenty of warm water containing a mild soapy detergent (or car body shampoo) and then rinse immediately with clean water, preferably using a hose pipe without power-washing. To further enhance the appearance of GRP we recommend the annual application of a coat of wax polish, e.g. a proprietary car body wax.

Any minor GRP surface blemishes can be restored using a proprietary cutting compound prior to applying a coat of polish.

- Plastic-Coating

Wash using a soft sponge mop and plenty of warm water containing a mild soapy detergent and then rinse immediately with clean water, preferably using a hose pipe without power-washing.

b) INTERNAL SURFACES

- Flecked Paint Walls

Clean using a sponge and warm water containing a mild soapy detergent.

- Plastic-Coating

Clean using a sponge and warm water containing a mild soapy detergent.

- WBP Plywood

Use a dry brush to wipe down.

c) GLAZING

- Toughened Glass & Thermoplastic

Clean using a sponge and warm water containing a mild soapy detergent and rinse immediately with clean water. Dry toughened glass using a chamois leather. Thermoplastic is very susceptible to scratching and marking, therefore, please clean with extreme care.

CAUTION!

1. For mild soapy detergents we recommend using proprietary household cleaners (or a car body shampoo for GRP) to the concentration as detailed on the manufacturer's instructions.
2. Do not use organic solvents or abrasive cleaners which can cause surface damage or colour fading.
3. Always clean from top to bottom and avoid over cleaning or scrubbing which can do more harm than good.

Routine Inspection of Moving Parts

During the routine cleaning process we recommend inspection and cleaning of all moving parts such as roller shutters, sliding windows, door handles, locks and hinges. The application of a proprietary light oil to item such as a roller shutter, door lock mechanisms and hinges will also help maintain their efficient operation.

Regular cleaning and lubrication where appropriate is essential to prevent an accumulation of dirt and debris can be detrimental to most moving parts and cause irreversible damage if left unattended.

Air Conditioning Systems

If an Air Conditioning System is installed in your Housing, the commissioning together with a 12 month maintenance and service agreement (via a third part provider) are normally included as standard. To ensure the safe and efficient operation of this equipment beyond the initial 12 month period, we strongly recommend that you make your own arrangements for an ongoing maintenance and service agreement directly with the existing provider or with an alternative qualified and competent source.

Warranty

Our standard warranty period is 12 months from the date of delivery and this covers the cost of any parts and labour required to rectify defects in material and workmanship supplied by Glasdon. This warranty does not extend to defects caused by abuse, exceptional usage and modifications or work undertaken by others.

Spares & Repairs

For replacement and spare parts and repair work etc please contact our Service Department.

5 Handling and Moving Your Product

To prevent damaging your Glasdon Housing whilst moving and handling, please follow these guidelines. If you are unsure about any aspect please contact our Transport Department and we will be delighted to assist.

General Principals

- Always use flat belt nylon slings.
- Always let the sling take the load.
- Use protective packing between the slings and product, where appropriate, to prevent damage.
- Always tie back the slings with care.
- Always pad the tie-back ropes to prevent damaging your product.
- Always lift slowly, carefully and safely.
- DO NOT USE CHAINS OR ROPES TO LIFT.
- DO NOT RUSH ANY PART OF THE LIFT.
- IF IN DOUBT PLEASE ASK.

To allow slings to be released easily after the lift, always lower the Housing on to temporary wedges.

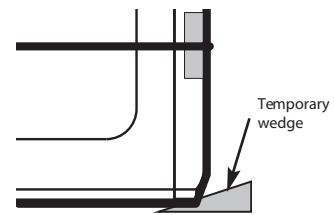

FORTRESS / GARRISON / TROOPER / DEFENDER

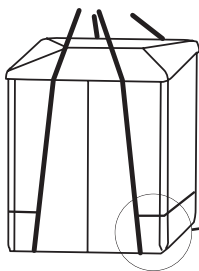

Position the slings at each end of the Housing approximately 250mm from the corners.

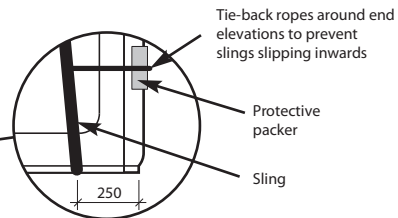

HERMIT

All Hermit Shelters are delivered in kit form ready for assembling directly on to your prepared concrete base. They are unsuitable for moving after assembly.

✓ RIGHT

✗ WRONG

FORK LIFT TRUCK

For small Housings only

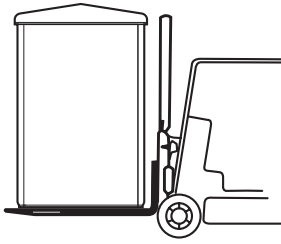

Always use fork extensions to lift across the full width of the Housing.

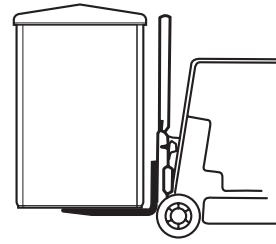

Short forks will damage the floor (if fitted) or will not support a Housing without a floor.

CRANAGE

Hook Height

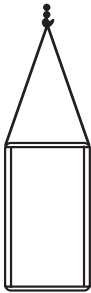

Always ensure high apex to the crane hook.



DO NOT use a low apex to the crane hook as it places a crushing effect upon the roof of the Housing.

Spreader Beams

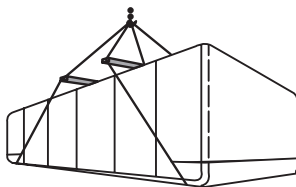

For some of our larger housings it may be necessary to use spreader beams - please contact our Transport or Technical Department for advice.

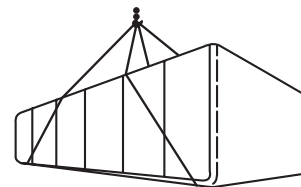

By not using spreaders correctly the load on the slings can produce a crushing effect upon the roof of the Housing.

Sling Security

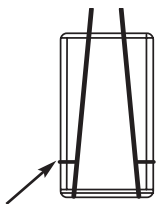

Slings must be seated at each end of the Housing and positioned approx. 250mm from the corner for maximum stability.

Tie-back ropes with protective packing

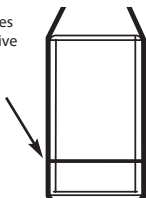

Always tension the slings before tying back and place tie-back ropes at low level to prevent the slings from slipping inwards as indicated on page 6.

Small Housings may require tighter roping.

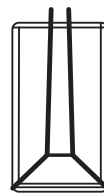

Too much tension on the tie-back rope may cause it to snap or the Housing to topple due to the lower centre of balance.



Slings positioned too close to the centre of the Housing will be unstable.

BLANK

BLANK

BLANK

Enclosed Documents for your Glasdon Housing

Customer

Glasdon Ref No.

Product Description

Product Brochure	<input type="checkbox"/>	Additional Items:	
CAD Layout Drawing	<input type="checkbox"/>	<input type="checkbox"/>
Electrical Test Certificate	<input type="checkbox"/>	<input type="checkbox"/>
Certificate of Compliance	<input type="checkbox"/>	<input type="checkbox"/>
On Site Assembly Instructions	<input type="checkbox"/>	<input type="checkbox"/>
Technical documentation for:		<input type="checkbox"/>
Consumer Unit	<input type="checkbox"/>	Documents prepared by:	
Lighting	<input type="checkbox"/>	
Heating	<input type="checkbox"/>	
Air Conditioning System	<input type="checkbox"/>	Date	

**Should you require any further assistance please contact us on
tel: 01253 600410, fax: 01253 792558 or email: sales@glasdon-uk.co.uk**



In accordance with our policy of continuous development and improvement, we reserve the right to make changes in design and specification without notice.

Glasdon UK Limited products are manufactured under license worldwide and carious components of the models are patented and design registered.



Glasdon®
Glasdon U.K. Limited
 Preston New Road
 BLACKPOOL
 Lancashire
 FY4 4UL
 Tel: (01253) 600410
 Fax: (01253) 792558
 e-mail: sales@glasdon-uk.co.uk
 web: www.glasdon.com