



ECO NEXUS™ CUP RECYCLING STATION

OPERATIONAL INSTRUCTIONS

Ensure that all personnel read the points listed within this leaflet and that a copy is given to staff involved with the installation and maintenance of this product. Glasdon recommends that a full Health and Safety analysis is carried out prior to use.

ECO NEXUS CUP STACKER

COMPONENTS:

- ITEM 1 - Lid
- ITEM 2 - Bin Body
- ITEM 3 - Sack Retention Slots
- ITEM 4 - Cup Stacking Tubes
- ITEM 5 - Internal Cradle
- ITEM 6 - Liquid Reservoir

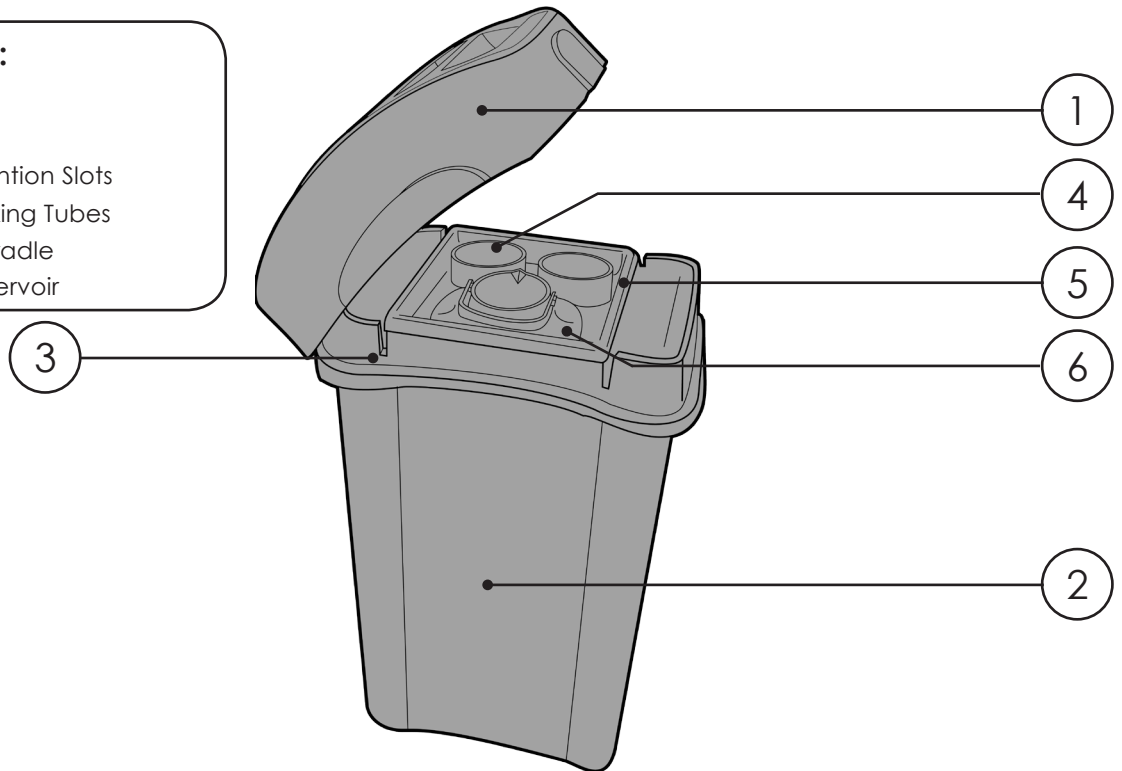

PLACING SACK INTO POSITION

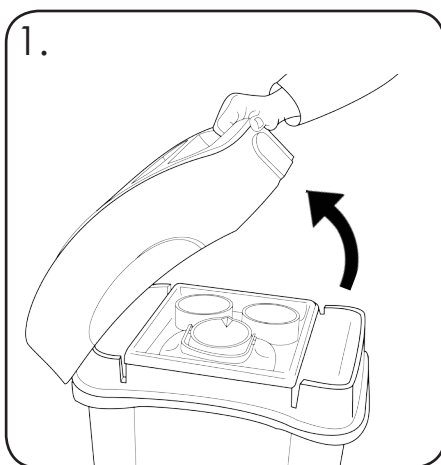

To access the internal compartments, lift the Lid (ITEM 1) off the Bin Body (ITEM 2).

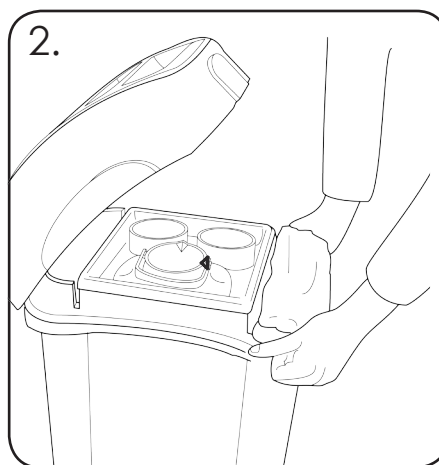

To install sacks, firstly insert into the Sack Retention Slots (ITEM 3) then stretch over the outer rim

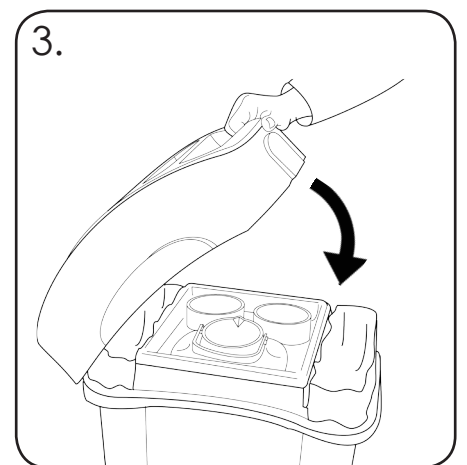

Lower Lid to replace, ensuring sacks are neatly secured underneath.

EMPTYING THE ECO NEXUS CUP STACKER

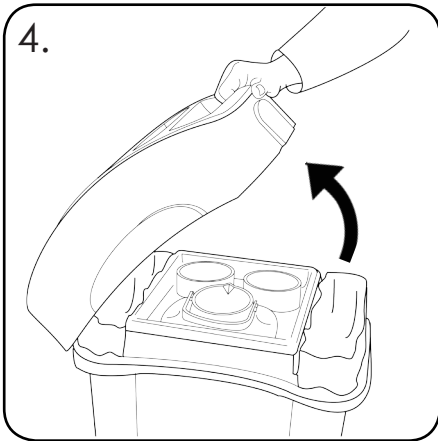

To access the internal compartments, lift the Lid off the Bin Body.

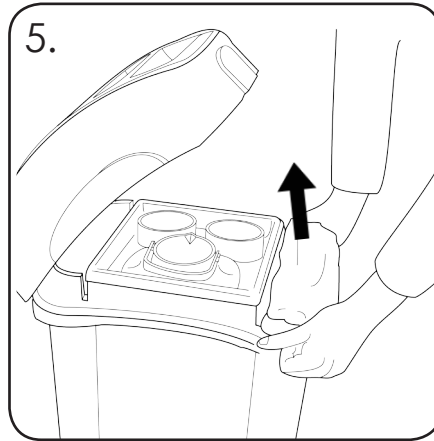

Release each sack individually from the bin rim and lift upwards out of the Bin Body.

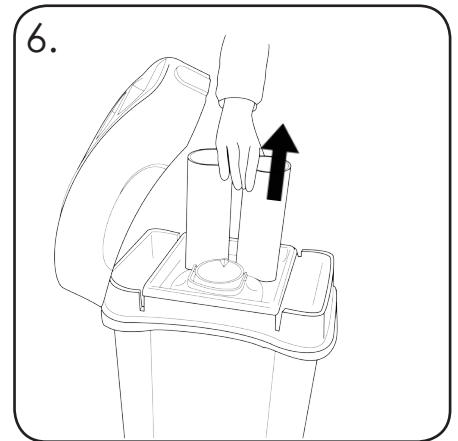

Remove the Cup Stacking Tubes (ITEM 4) by lifting upwards, pulling them out of the Internal Cradle (ITEM 5).

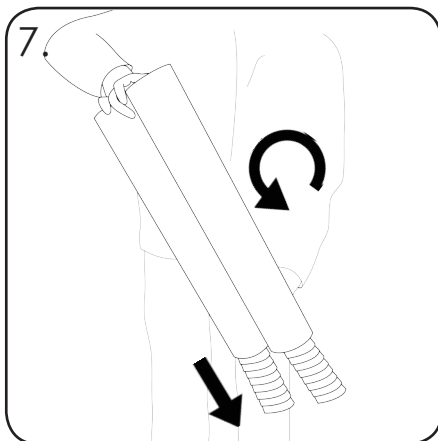

Rotate the Cup Stacking Tubes 180 degrees to allow the stacks of cups to be removed.

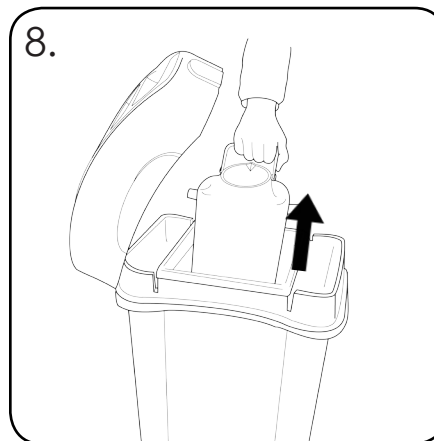

Remove the Liquid Reservoir (ITEM 6) by lifting upwards, pulling them out of the Internal Cradle.

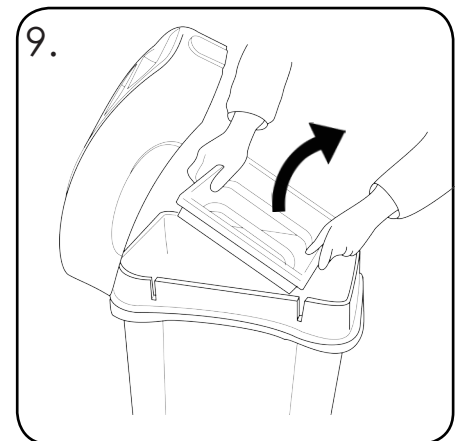

Remove the Internal Cradle by pulling it out of the Sack Retention Slots in the Bin Body.

ATTACHING THE WHEELS

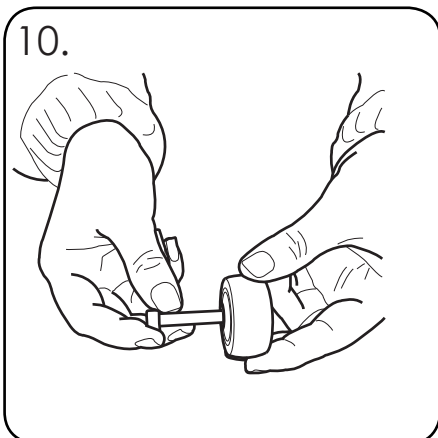

From kit provided, place 1 screw through a wheel.

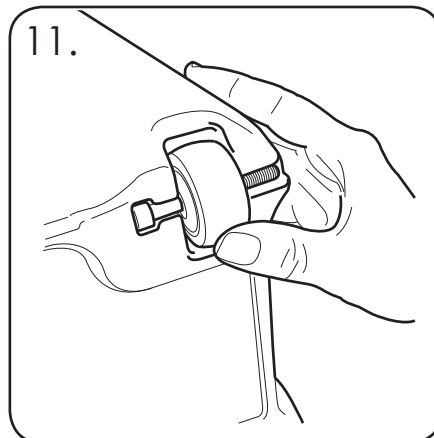

With bin body upside down, click screw and wheel into moulded slot. Repeat with second wheel.

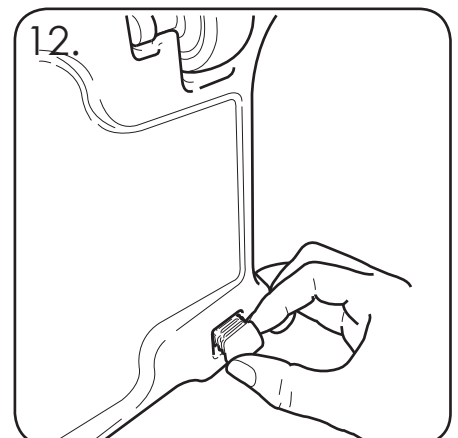

Push both socket caps into the moulded recesses opposite wheels.



ECO NEXUS™ CUP RECYCLING STATION

SIGN KIT INSTALLATION INSTRUCTIONS

Ensure that all personnel read the points listed within this leaflet and that a copy is given to staff involved with the installation and maintenance of this product. Glasdon recommends that a full Health and Safety analysis is carried out prior to installation.

ECO NEXUS CUP STACKER

COMPONENTS:

ITEM 1 - Socket Screw	x 1
ITEM 2 - Extruded Spacer	x 1
ITEM 3 - Foamex Sign	x 1
ITEM 4 - Nyloc Nut M6	x 1
ITEM 5 - Washer M6	x 2
ITEM 6 - Screw M6	x 2
ITEM 7 - Spacer	x 2
ITEM 8 - Lug Nut	x 2

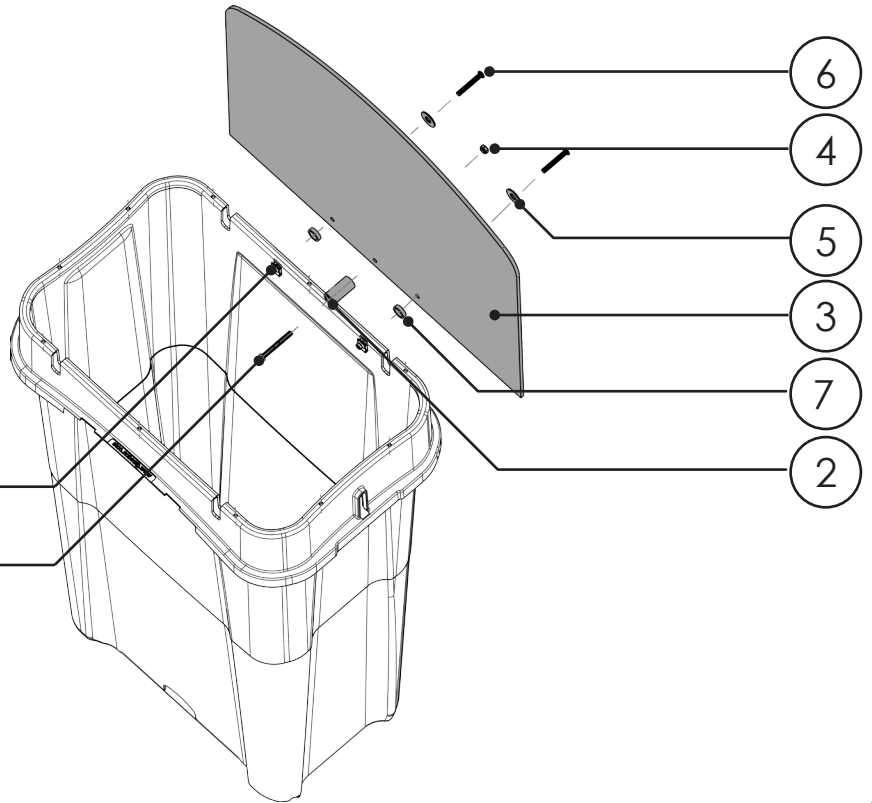

TOOLS REQUIRED:

4mm Allen Key

INSTALLING THE SIGN KIT

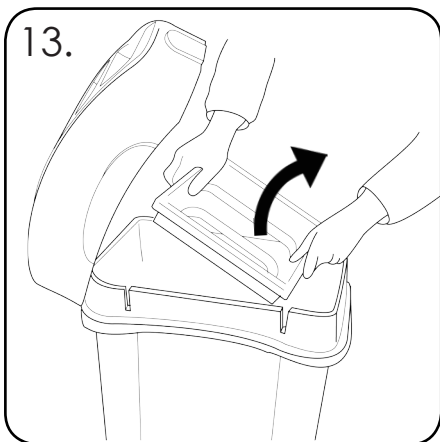

13. Empty the internal components from the inside of the Bin Body. See steps 4-9 to assist in emptying the bin.

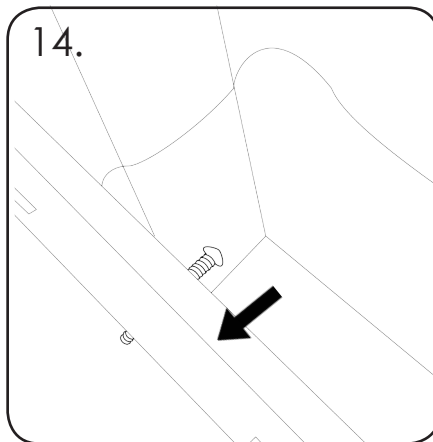

14. From the inside of the Bin Body thread the Socket Screw (ITEM 1) through the Bin.

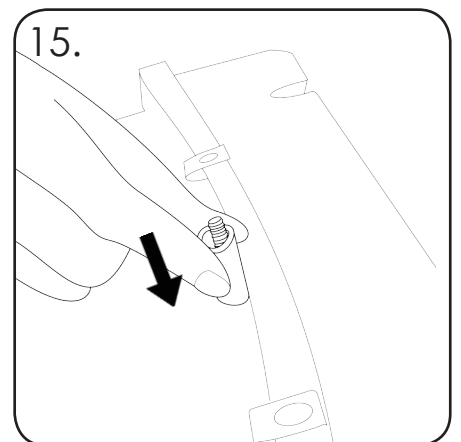

15. Lay the Bin Body on its side on a soft floor surface. From the outside of the Bin Body place the Extruded Spacer (ITEM 2) onto the Socket Screw

INSTALLING THE SIGN KIT

16.

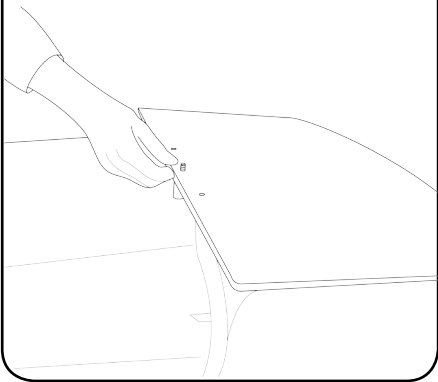

Place the Foamex Sign (ITEM 3) onto the Socket Screw ensuring the graphic side is face down.

17.

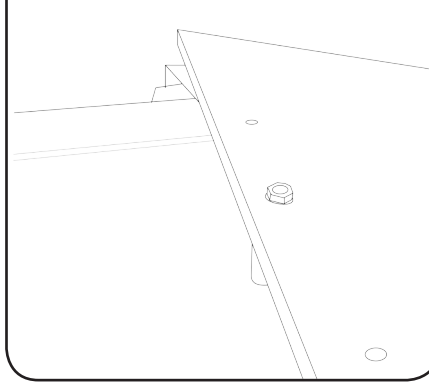

Thread the Nyloc Nut M6 (ITEM 4) onto the Socket Screw, lightly tighten by hand.

18.

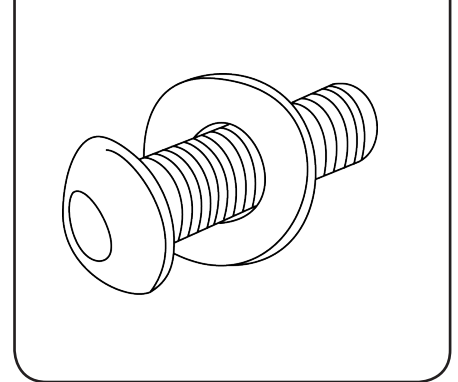

Assemble the fixings as shown placing the Washer M6 (ITEM 5) onto the Screw M6 (ITEM 6)

19.

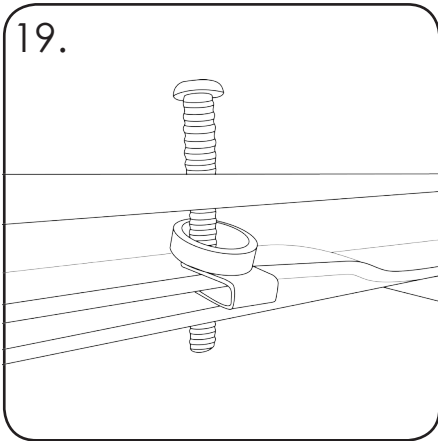

Place the spacer (ITEM 7) between the Lug Nut (ITEM 8) and the Foamex Sign. Thread the assembled fixings through the Foamex Sign and lightly tighten by hand.

20.

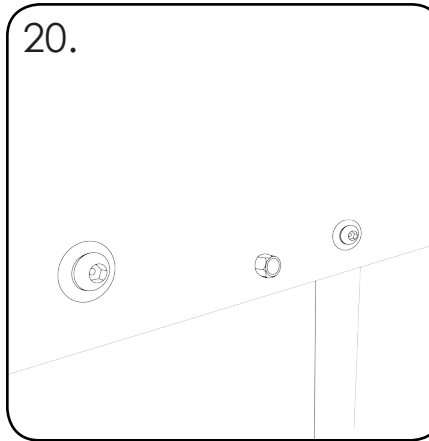

Repeat steps 18-19 for both fixing points. Securely tighten the fixings with the Allen Key.

 **Glasdon**, CENTRUM AND NEXUS ARE TRADEMARKS OR REGISTERED TRADEMARKS OF GLASDON GROUP OR ITS SUBSIDIARIES IN THE U.K. AND OTHER COUNTRIES

- A planned maintenance schedule or regular inspection is recommended, replacing components as necessary.
- Replacement components are available direct from GLASDON.
- GLASDON cannot be held responsible for claims arising from incorrect installation, unauthorised modifications or misuse of the product.

Issue 1 - November 2017 - Stock No. C000/0511 - DWG No. 07B338-64

© Copyright November 2017

Glasdon UK Ltd reserve the right to alter specifications without prior notice.

 **Glasdon**[®]
Glasdon U.K. Limited

Preston New Road
BLACKPOOL
Lancashire
FY4 4UL

Tel: (01253) 600410
Fax: (01253) 792558
e-mail: sales@glasdon-uk.co.uk
web: www.glasdon.com