

Courbe™

INSTALLATION & OPERATOR INSTRUCTIONS

IMPORTANT NOTE: ENSURE THAT ALL RELEVANT PERSONNEL READ THESE INSTRUCTIONS PRIOR TO USE

IMPORTANT NOTE:



THE BIN MUST BE SITED ON LEVEL GROUND. IF YOU ARE NOT USING GLASDON FIXINGS SUPPLIED WITH THE PRODUCT YOU MUST ENSURE THAT 35MM DIAMETER WASHERS ARE USED IN ORDER TO SECURE THE BIN WHEN GROUND FIXING.



We recommend that a risk assessment is undertaken to identify an appropriate location for your waste collection and recycling units. In order to reduce risk, some organisations decide to place the units a minimum of 5 metres away from buildings.

KIT CONTENTS:

ITEM 1 - Courbe Litter Bin	x 1
ITEM 2 - M10 x 60mm Ground Anchor Bolt	x 4
ITEM 3 - M10 x 35mm Washer	x 4
ITEM 4 - M10 Ground Anchor Sleeve	x 4

EQUIPMENT REQUIRED:

- Felt Tip/Marker Pen	x 1
- Hand Held Hammer Drill	x 1
- 16mm Dia. Masonry Drill Bit	x 1
- 17mm Spanner or Socket Set	x 1

1

GROUND FIXINGS:

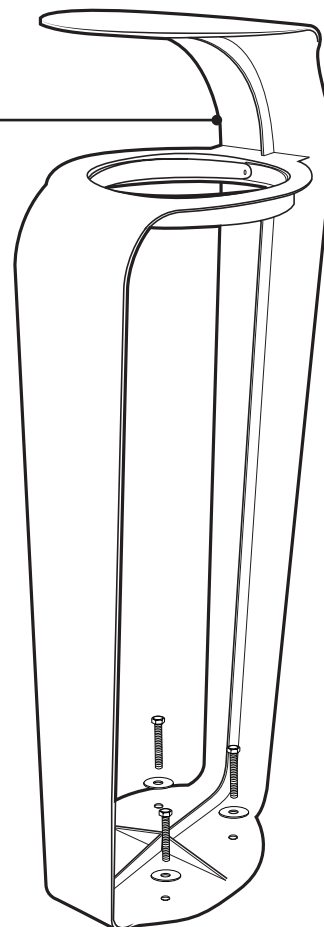
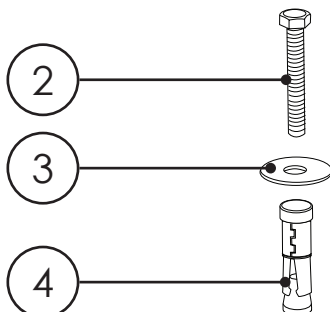

DIAGRAM NOT TO SCALE

INSTALLATION INSTRUCTIONS

Place the bin in the desired location. Inspect the condition of the concrete you wish to install in to. If installing into paving slabs - ensure fixings are not positioned within 110mm of the edge of a slab (as doing so may cause the slab to break).



Position the bin [ITEM 1]. Using a pen mark the positions of the four ground fixing holes in the base onto the ground below.

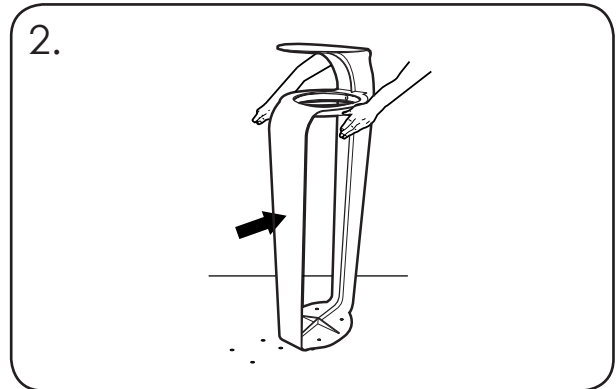

Move the bin to one side.

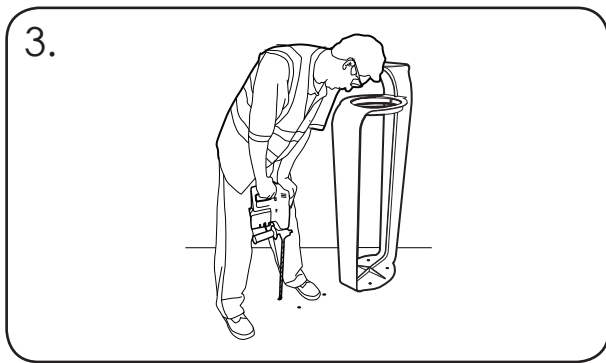

Drill the holes to a depth of 80mm using the 16mm drill bit. Afterwards, take care to ensure the concrete dust is removed from the holes.

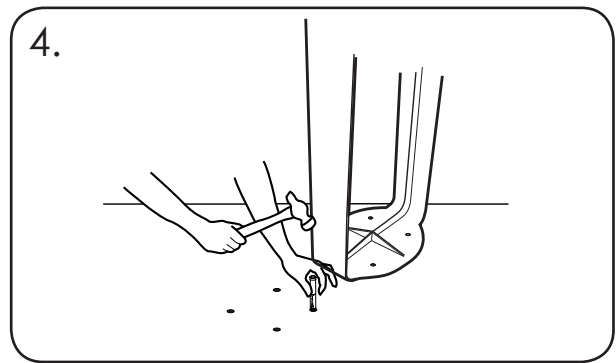

Hammer in the anchor sleeves [ITEM 4] into the drilled holes until the top of the sleeve is level with the ground.

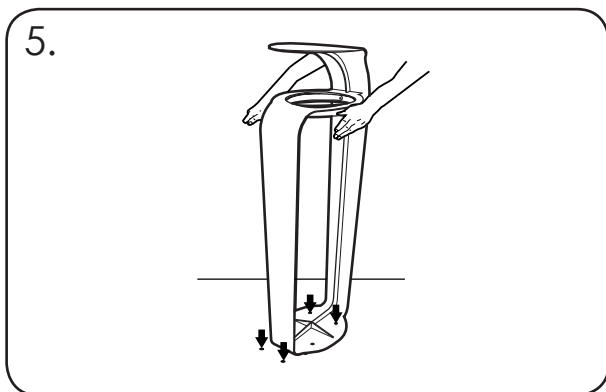

Reposition the bin over the drilled holes.
Place the washers [ITEM 3] onto the bolts [ITEM 2].

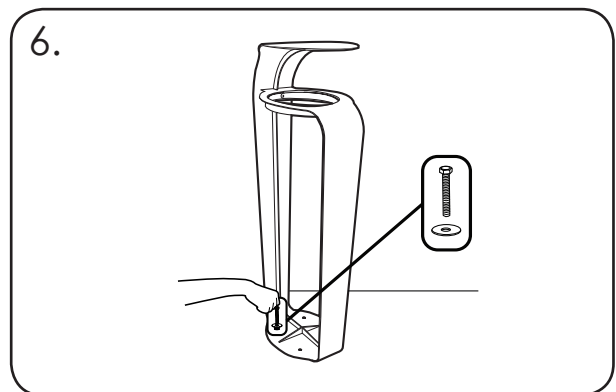

Insert the bolts through the ground fixing holes in the bin into the anchor sleeves in the ground.
Tighten by hand to start with.

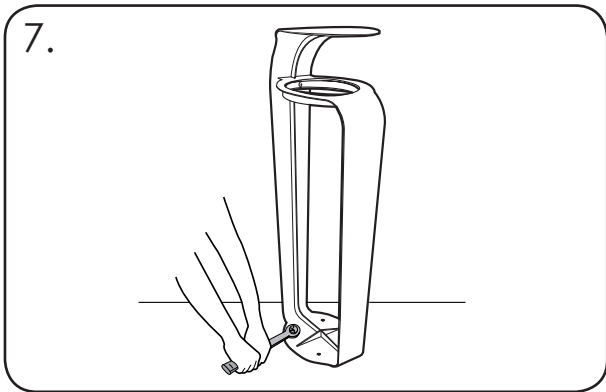

Tighten the bolts into the ground using a 17mm spanner or socket set.

OPERATOR INSTRUCTIONS

Inserting a Sack



Lift the two sack bands upwards.



Feed the sack up through the sack bands from beneath. Wrap the top of the sack over both bands.



Push the sack bands down to trap the sack between the bands and the sack ring, clamping it in an open position ready for use.

To replace a sack, follow the same process, only remove the sack during STEP 1.

IMPORTANT NOTE: PLEASE ENSURE THAT ALL RELEVANT PERSONNEL READ THE POINTS LISTED WITHIN THIS LEAFLET AND THAT A COPY IS GIVEN TO STAFF INVOLVED WITH THE INSTALLATION AND MAINTENANCE OF THIS PRODUCT.

SAFETY NOTE: PLEASE REFER TO RELEVANT MANUAL HANDLING OPERATIONS REGULATIONS DURING HANDLING.



Glasdon AND COURBE ARE TRADEMARKS OR REGISTERED TRADEMARKS OF GLASDON GROUP OR ITS SUBSIDIARIES IN THE U.K. AND OTHER COUNTRIES

- A planned maintenance schedule or regular inspection is recommended, replacing components as necessary.
- Replacement components are available direct from GLASDON.
- GLASDON cannot be held responsible for claims arising from incorrect installation, unauthorised modifications or misuse of the product.

Stock No. C000/0496 - DWG No. 07B-363-16 Issue 1 - June 2017

© Copyright June 2017

Glasdon UK Ltd reserve the right to alter specifications without prior notice.



Glasdon[®]

Glasdon U.K. Limited

Preston New Road
BLACKPOOL
Lancashire
FY4 4UL

Tel: (01253) 600410

Fax: (01253) 792558

e-mail: sales@glasdon-uk.co.uk

web: www.glasdon.com